

## Specifications

|                             |   |
|-----------------------------|---|
| <b>Voltage:</b>             | 240 Volts AC 50Hz<br>- Single Phase   |
| <b>Power:</b>               | 150 V.A.  |
| <b>Weight:</b>              | 90kg  |
| <b>Vault</b>                | High capacity vault with key lock<br>and easy coin removal. Steerable<br>wheels and integral pulling handle.              |
| <b>Receipt Printer:</b>     | 80mm Thermal, with guillotine,<br>extra large paper roll with 'low<br>paper' sensing.                                     |
| <b>Coin counting speed:</b> | 500 coins per minute with<br>foreign coin recognition   |
| <b>Note Acceptance:</b>     | Single note. 4 ways entry.<br>1.1 Seconds per note with Stacker<br>Cassette. 500/1200 note stacker or<br>6000 note vault. |
| <b>Screen:</b>              | 12.1" (30.8cm) Colour TFT   |

### Dimensions:

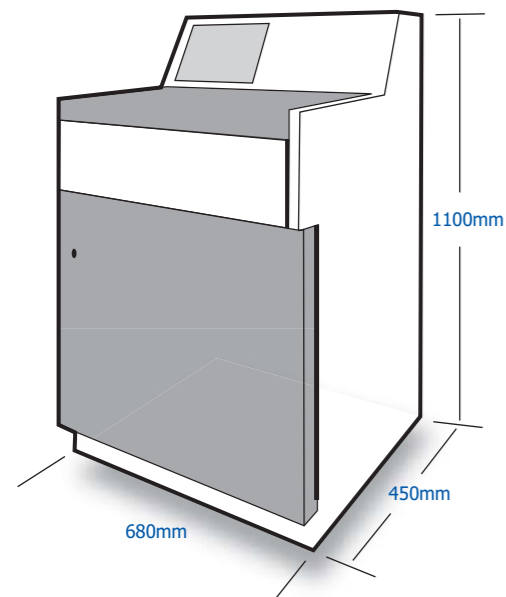

RoHS  
CERTIFIED

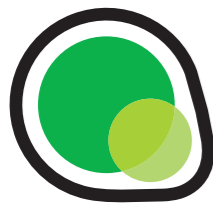

**AutoCash**<sup>TM</sup>  
AUTOMATED COUNTING SOLUTIONS

**AutoCash Ltd,**  
28 Shenley Road,  
Borehamwood WD6 1DR  
Tel/Fax: +44 (0)208 236 0164  
Email: [info@coinsort.org](mailto:info@coinsort.org)  
[www.auto-cash.co.uk](http://www.auto-cash.co.uk)



# time for change

## Increase productivity more profitably

With the circulation of cash increasing globally companies and charity organisations are seeking a fast and effective way of managing cash transactions. AutoCash<sup>TM</sup> - automated counting solutions save you time and money.

Cash automation provides the following benefits:

- Simple cash management
- Menu driven cash deposits
- Up to date monitoring on all financial transactions
- Comprehensive reporting facilities
- Free-standing or through-the-wall installation
- Integral Keyboard for fast data input/output

"AutoCash<sup>TM</sup> successfully provides businesses with a fast, reliable and accurate cash handling solution."



Designed & manufactured  
in the United Kingdom

BANKS

CASINOS

CHURCHES

FOOTBALL CLUBS

LOCAL AUTHORITIES

PUBLIC TRANSPORT

RETAILERS

SHOPPING MALLS

SUPERMARKETS



**Optional note vault**

Removable and stores up to 500 or 1200 notes.



**Large volume coin tray**

Prepares coins for counting process with 40° tilting action.



**12.1" colour TFT**

Simple to use on-screen instructions and transaction display



**Receipt printer**

27cm diameter easy change paper roll with guillotine and low paper sensor.  
**Print and eject function** - eliminates tearing and roll pull.

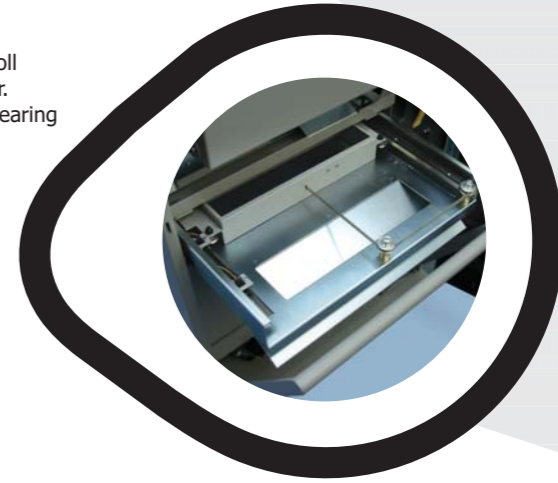

**Optional escrow**

Allows user to repeat counts without depositing coins in to the vault

Introducing the

**cn700**

**Coin and note deposit system**



- **Accurately processes 500CPM** (Coins per minute)
- **Digital parameter reading with alloy sensing**
- **Large colour TFT**
- **Easy to use**
- **'Self Calibrating' mode**
- **Large volume coin tray**
- **Front or rear loading vault**
- **Simple keyboard operation**
- **Receipt printer**
- **Dual line display** (for maintenance use)
- **12 months warranty**

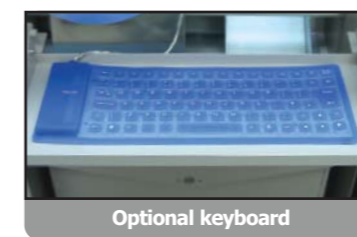

Optional keyboard



Manual debit, credit and token entry



Easy to follow screen instructions

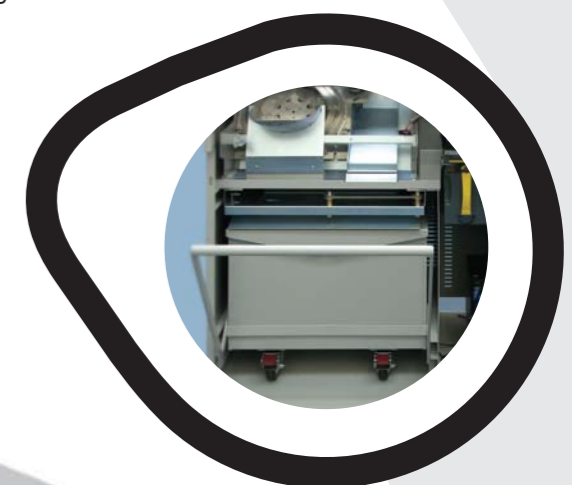

**Coin vault**

Secure 66 litre front or rear entry (construction) vault with steerable locking wheels and Integral pulling handle.

**Features:** Coin capacity sensing and removal logging